

PART NUMBER	DESCRIPTION	MAX PSI	PIPE SIZE	OPENING THRU BALL
DM200ASS	2" Male x FPT NPT with PTFE Seals	150	2"	1½"
DM200ABSS	2" Male x FPT BSP with PTFE Seals	150	2"	1½"
DM200DSS	2" Female x FPT NPT with PTFE and FKM Seals	150	2"	1½"
DM200DBSS	2" Female x FPT BSP with PTFE and FKM Seals	150	2"	1½"
DM200DBSSE	2" Female x FPT BSP with PTFE and EPDM Seals	150	2"	1½"
DM200DBSST	2" Female x FPT BSP with PTFE and Kalrez® Seals	150	2"	1½"

*Female refers to DM100DSS, DM150DSS and DM200SS variants. **Male refers to DM100ASS, DM150ASS and DM200ASS variants.

WARNINGS



WARNING

Dry Mate Dry Disconnects should be used, inspected, serviced and rebuilt only by persons who have been properly trained and instructed on their use, inspection, servicing and rebuilding.

The Banjo DM100SS, DM150SS & DM200SS Series should not be used at pressures above the Maximum Pressure or at temperatures above the Maximum Temperature or below the Minimum Temperature indicated. Use outside of these parameters could cause failure of the fittings, which may result in significant injury or death.

Although sold separately, the Male should only be used with the Female, and the Female should only be used with the Male.

The Banjo DM100SS, DM150SS & DM200SS Series should not be used with chemicals or other fluids with which it is not compatible. Before use, confirm compatibility of the chemical or other fluid being transferred with the materials used in the Banjo DM100SS, DM150SS & DM200SS Series.



OPERATION WARNING

Make sure the cam arms are in the fully locked position as shown in Figure 2 before attempting to rotate the handle of either the Male or Female.

As the handle of the Female is being closed and before the handle is fully closed, the locking yoke that prevents the cam levers from being opened will disengage.

Make sure that the handle on the Female is fully closed before opening the cam arms.

If the cam arms are opened before the handle of the Female is fully closed, liquid may spray or be discharged, which may result in significant injury or death.



INSTALLATION WARNING

When installing the couplers, use a good quality thread sealant compatible with the liquid being used in the system. Screw the coupler onto the thread hand tight; using a wrench, tighten the coupler onto the thread another 1/4 to 1/2 turn.

The Male should always be installed on the high-pressure side of the system. Failure to install the Male on the high-pressure side can trap pressurized fluid between the balls, causing fluid to spray when the two halves are disconnected, which may result in significant injury or death!

Never open Male or Female couplings when disconnected. High-pressure fluid can be retained inside valve causing injury if opened while not connected to a mating coupler. Inspect all safety interlocks daily. If any of the safety features are not functioning or are damaged, unit must be repaired before using in service. Inspect cam and mating ribs for damage and wear. Bent or damaged parts as well as excessive wear can adversely affect product performance. Inspect seals and sealing area on faces of couplers for any signs of damage. All surfaces should be clean and damage free prior to connection.



DISASSEMBLY WARNING

Make sure the Dry Mate is flushed clean of chemicals and other fluids before any rebuild or seal replacement.

OPERATION

STEP 1

To attach the two fittings together, make sure the faces of the two fittings are free from dirt or other foreign material. Make sure the seal is properly installed and without damage. Align the two fittings together as shown in Figure 1.

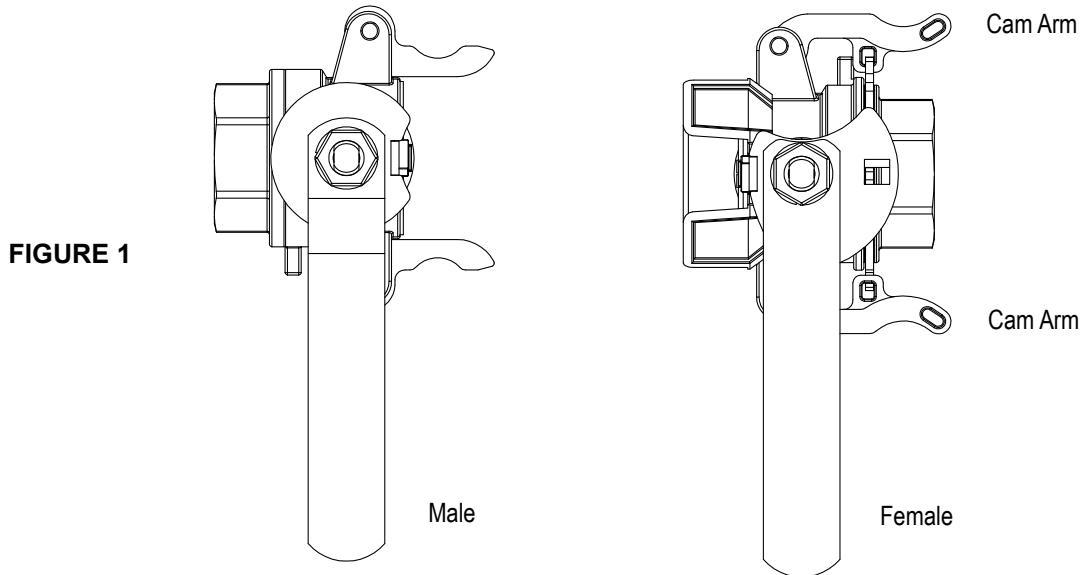

STEP 2

Slide the Female onto the Male. The alignment tabs on the Female will guide the cam profile inserts into the cam arms of the Female. After the assembly is together, rotate the cam arms toward the body of the Female. Make sure the cam arms are pushed all the way to the female body. This will couple the halves together, depressing the anti-rotation buttons under the handles, which will allow the handles to rotate. After the clamp arms are rotated in position, the assembly should look like Figure 2.

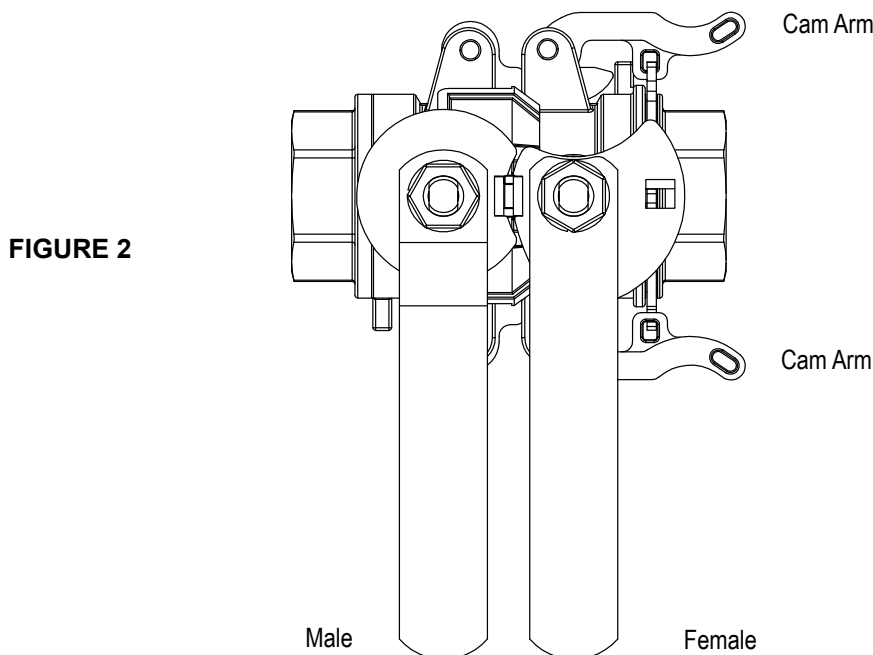

STEP 3

In this position, the handle of the Female must be rotated before the handle of the Male can rotate. Rotate the handle of the Female to the fully open position. When the female handle is fully opened, the locking yoke will engage the clamp arms and prevent the clamp arms from being opened while the handle is in the fully open position. The handles should now be oriented as shown in Figure 3.

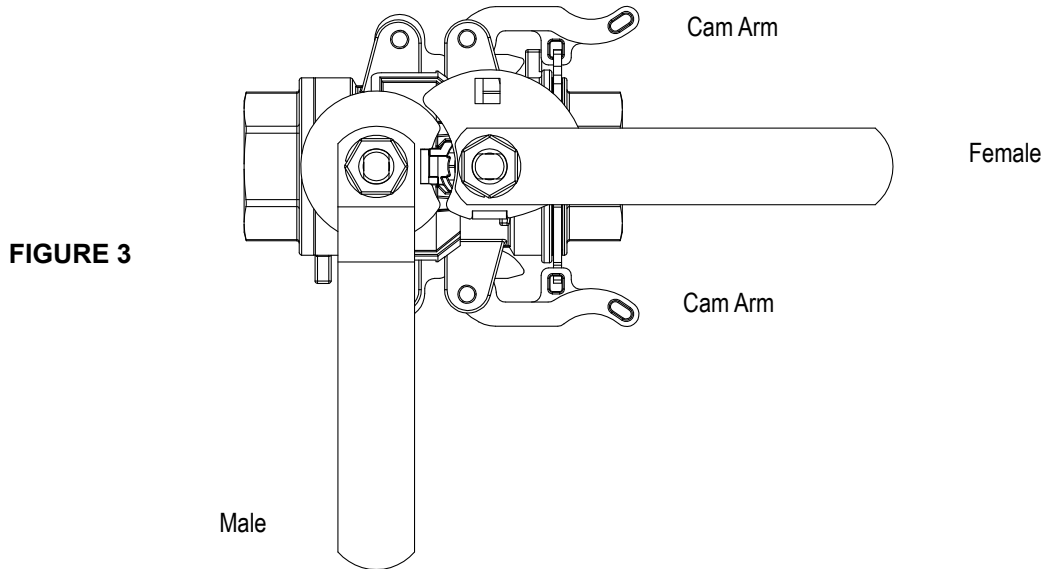

STEP 4

After the handle of the Female has been fully opened, the handle of the Male can be rotated. Rotate the handle of the Male to the fully open position. The assembly is now opened and flow may begin. When both valves are fully opened the handles should be oriented as shown in Figure 4.

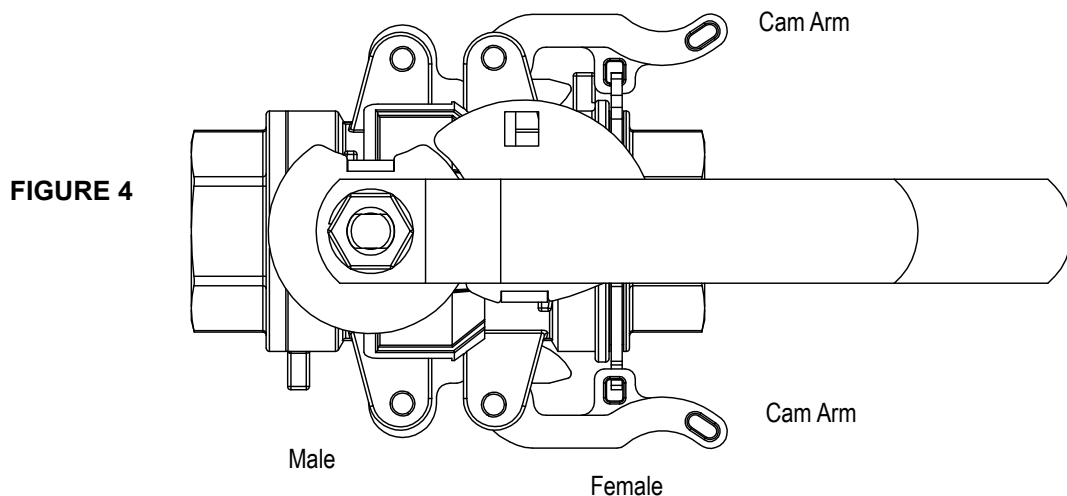

To close the valves and disconnect the couplers, reverse steps 1 through 4.

DISASSEMBLY INSTRUCTIONS

STAINLESS STEEL DRY MATE REBUILD INSTRUCTIONS *Applies to Male (A) half only*

1. Remove the end plate by holding the body with a bench vise and turning the end plate by the wrench flats. The end plate has right hand threads.
2. Remove the ball. The handle should be in the closed position when removing the ball. The ball should slide out easily.
3. Remove the old seat that goes between the body and the ball.
4. Install the new seat.
5. Reinstall the ball. Check for pits, scrapes, or any other damage. If damaged or worn, replace ball.
6. Replace old seat in end plate with new seat.
7. Replace old body gasket with a new gasket.
8. Reinstall end plate on valve. Before tightening the end plate, make sure that the handle and ball are in the closed position. Tighten end plate to 325 Ft-lb of torque for 1 ½" and 2" Dry Mate. Tighten end plate to 150 Ft-lb of torque for the 1" Dry Mate.
9. Check to make sure the dry mate half is functional and all the safety features are working properly.

STAINLESS STEEL DRY MATE FACE SEAL REPLACEMENT INSTRUCTIONS *Applies to Female (D) half only*

1. Remove the end plate by holding the body with a bench vise and turning the end plate by the wrench flats. The end plate has right hand threads. Pay attention to the orientation of the locking yoke as you remove the end plate.
2. Remove the ball. The handle should be in the closed position when removing the ball. The ball should slide out easily.
3. Remove the seat that goes between the Face Seal and the ball.
4. Remove the old Face Seal from the Dry Mate body, paying attention to how it sets in the valve body.
5. Install the new Face Seal.
6. Install the seat. Inspect the old seat for damage or wear. If damaged or worn, replace with new seat.
7. Reinstall the ball. Check for pits, scrapes, or any other damage. If damaged or worn, replace ball.
8. Check seat in end plate for wear or damage. If worn or damaged, replace with new seat.
9. Check Body Gasket for wear or damage. If worn or damaged, replace with a new gasket.
10. Make sure locking yoke is still on the end plate. Reinstall end plate on valve, checking to see that the orientation of the locking yoke matches the original orientation. Before tightening the end plate, make sure that the handle and ball are in the closed position. Tighten end plate to 325 Ft-lb of torque for 1 ½" and 2" Dry Mate. Tighten end plate to 150 Ft-lb of torque for the 1" Dry Mate.
11. Check to make sure the dry mate half is functional and all the safety features are working properly.

Please see banjocorp.com for more product drawings.



BANJO CORPORATION

A Unit of IDEX Corporation
150 Banjo Drive
Crawfordsville, IN 47933 U.S.A.
Telephone: (765) 362-7367
Tech Sales: (888) 705-7020
Fax: (765) 362-0744
banjocorp.com

