

DM220SS SERIES

2" FULL PORT STAINLESS STEEL

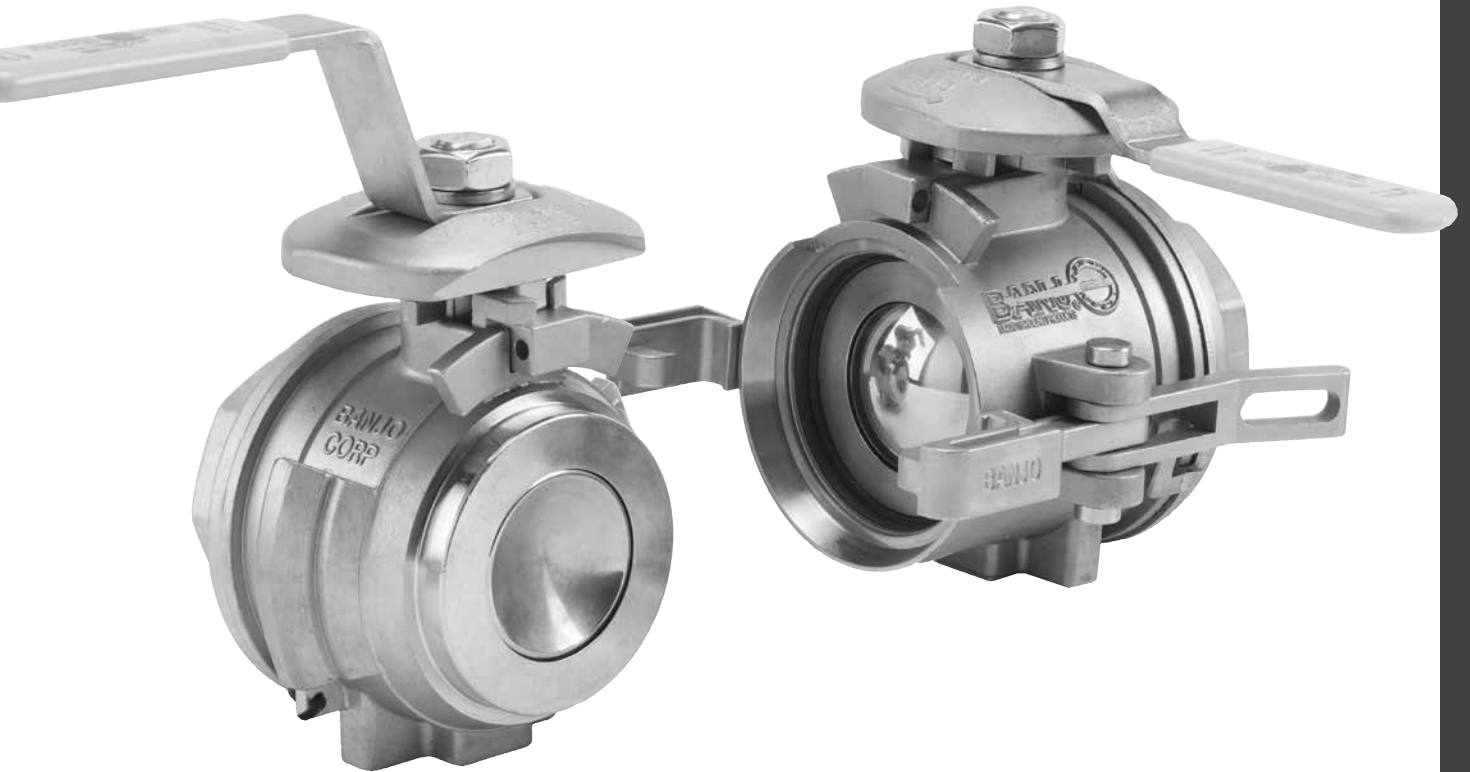

OVERVIEW

The Banjo DM220SS Series of dry quick disconnect fittings is designed to handle many of the industrial chemicals in use today with a minimum of fluid spillage. The easy to use ball valve design of the fittings allows an unrestricted path for fluid flow.

The handles interlock making it easy to identify which handle opens or closes first.

The Dry-Mate is constructed of 316 stainless steel for strength and excellent chemical resistance. The PTFE seats and FKM face seal on the female give the Dry-Mate the same chemical resistance as Banjo's standard line of ball valves. The face seal on the female is available in FKM, EPDM and Kalrez®. The male has all PTFE sealing components.

The over center clamps are easy, quick and positive engagement of the Dry-Mate components. The clamps are 316 stainless steel for maximum corrosion resistance. The clamps are easily replaceable if damaged.

The Female* has a groove that mates to a rib on the male to provide correct alignment during assembly with the Male**. The two halves may be rotated 10 degrees either direction with respect to each other and still be clamped together and function properly.

The DM220SS Series has many safety features to reduce the risk of accidental spillage. Both handles have interlock buttons, which prevent the handles from opening when the halves are separated and the handles are in the fully closed position. The Female also has a 316SS yoke which keeps the clamp arms in the locked position when the couplers are connected and the handle is in the fully open position. This prevents the couplers from being separated when the handles are in the fully open position. The gasket that seals between the two components is mechanically secured to ensure that the gasket stays in place when the halves are disconnected.

Both the Male and Female come standard with a dust cover to keep the balls and seals protected when not in use.

SPECIFICATIONS

Maximum Pressure 300 PSI @ 70° F Minimum Temperature -20°F @ 200 PSI Maximum Temperature 300° @ 200 PSI

PART NUMBER	DESCRIPTION	MAX PSI	PIPE SIZE	OPENING THRU BALL
DM220ASS	2" Male x FPT NPT with PTFE Seals	300	2"	2"
DM220ABSS	2" Male x FPT BSP with PTFE Seals	300	2"	2"
DM220DSS	2" Female x FPT NPT with PTFE and FKM Seals	300	2"	2"
DM220DBSS	2" Female x FPT BSP with PTFE and FKM Seals	300	2"	2"
DM220DBSST	2" Female x FPT NPT with PTFE and Kalrez® Seals	300	2"	2"

*Female refers to DM220DSS variants. **Male refers to DM220ASS variants.

WARNINGS



WARNING

Dry Mate Dry Disconnects should be used, inspected, serviced and rebuilt only by persons who have been properly trained and instructed on their use, inspection, servicing and rebuilding.

The Banjo DM220SS Series should not be used at pressures above the Maximum Pressure or at temperatures above the Maximum Temperature or below the Minimum Temperature indicated. Use outside of these parameters could cause failure of the fittings, which may result in significant injury or death.

Although sold separately, the Male should only be used with the Female, and the Female should only be used with the Male.

The Banjo DM220SS Series should not be used with chemicals or other fluids with which it is not compatible. Before use, confirm compatibility of the chemical or other fluid being transferred with the materials used in the Banjo DM220SS Series.



OPERATION WARNING

Make sure the clamp levers are in the fully locked position as shown in Figure 3 before attempting to rotate the handle of either the Male or Female.

As the handle of the Female is being closed and before the handle is fully closed, the locking yoke that prevents the clamp levers from being opened will disengage.

Make sure that the handle on the Female is fully closed before opening the clamp levers.

If the clamp levers are opened before the handle of the Female is fully closed, liquid may spray or be discharged, which may result in significant injury or death.



INSTALLATION WARNING

When installing the couplers, use a good quality thread sealant compatible with the liquid being used in the system. Screw the coupler onto the thread hand tight; using a wrench, tighten the coupler onto the thread another 1/4 to 1/2 turn.

The Male should always be installed on the high-pressure side of the system. Failure to install the Male on the high-pressure side can trap pressurized fluid between the balls, causing fluid to spray when the two halves are disconnected, which may result in significant injury or death!

Never open Male or Female couplings when disconnected. High-pressure fluid can be retained inside valve causing injury if opened while not connected to a mating coupler. Inspect all safety interlocks daily. If any of the safety features are not functioning or are damaged, unit must be repaired before using in service. Inspect cam and mating ribs for damage and wear. Bent or damaged parts as well as excessive wear can adversely affect product performance. Inspect seals and sealing area on faces of couplers for any signs of damage. All surfaces should be clean and damage free prior to connection.



DISASSEMBLY WARNING

Make sure the Dry Mate is flushed clean of chemicals and other fluids before any rebuild or seal replacement.

OPERATION

STEP 1

To attach the two halves together, make sure the faces of the Male and Female are free from dirt or other foreign material. Align the two halves together as shown in Figure 1. The two halves can be rotated 10 degrees either direction with respect to each other as shown in Figure 2.

FIGURE 1

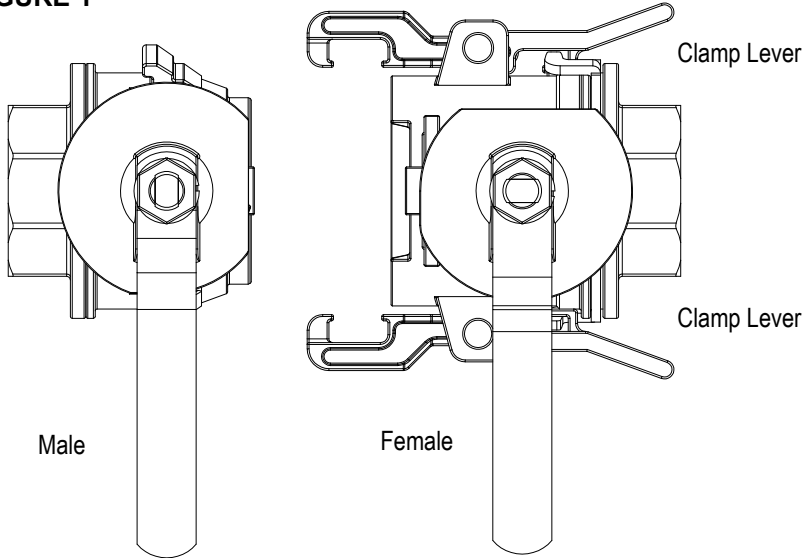
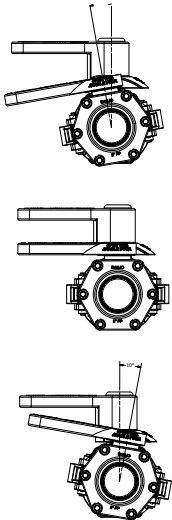

FIGURE 2



STEP 2

Slide the Female onto the Male. The alignment groove on the Female will guide the male half into the female half. After the assembly is together, latch the clamp arms onto the mating rib on the male and rotate the clamp lever toward the female body. This will couple the halves together and depress the anti-rotation buttons under the handles, which will allow the handles to rotate. After the two halves are clamped together, the assembly should look like Figure 3.

FIGURE 3

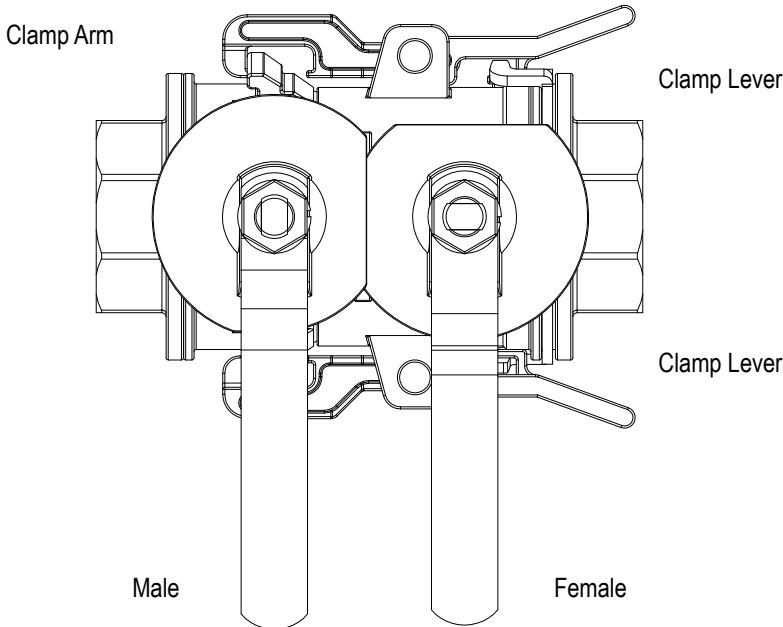

STEP 3

Rotate the handle of the Female to the open position. The female handle must be rotated before the handle of the Male can rotate. When the female handle is fully opened, the locking yoke will engage the clamp lever and prevent the clamp lever from opening while the female handle is in the fully open position. The handles should now be oriented as shown in Figure 4.

FIGURE 4

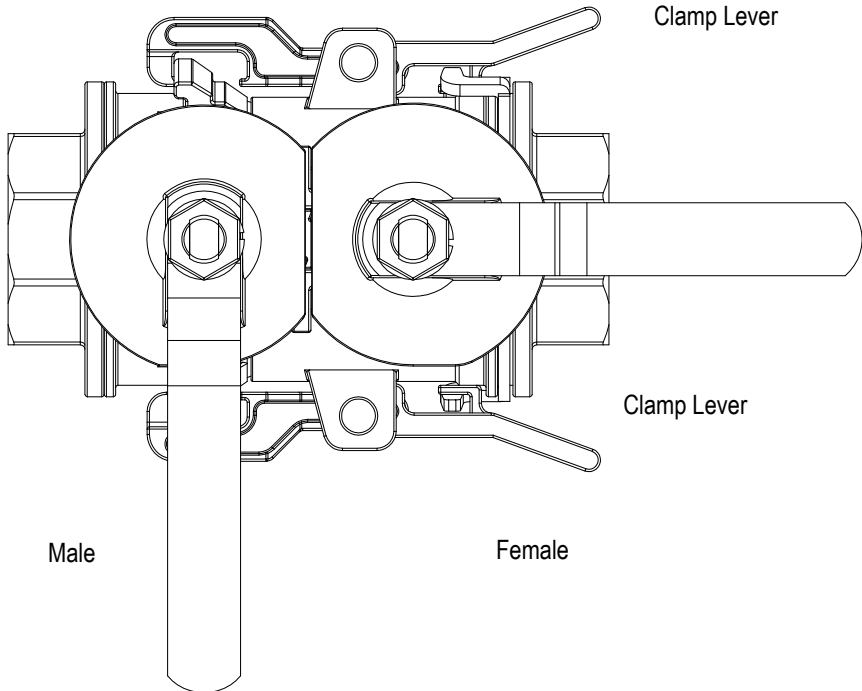

STEP 4

After the handle of the Female has been fully opened, the handle of the Male can be rotated open. Rotate the handle of the Male to the fully open position. Flow will start as the male handle is being opened. When both valves are fully opened the handles should be oriented as shown in Figure 5.

FIGURE 5

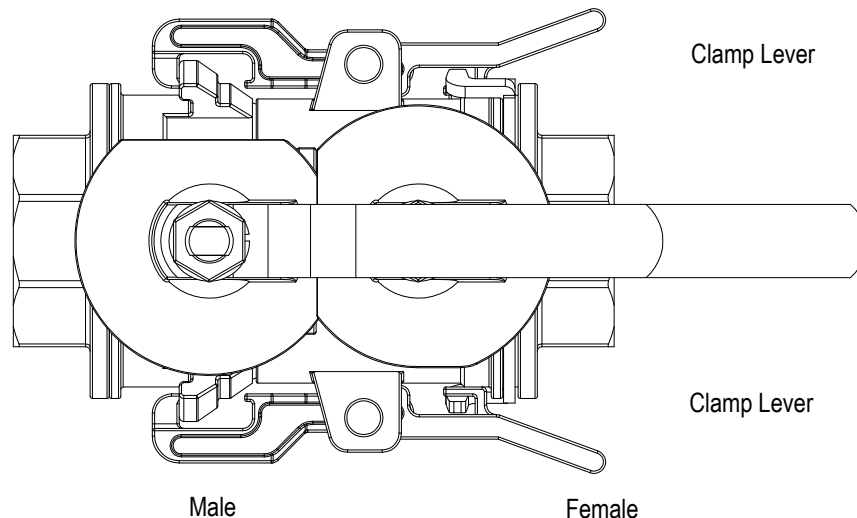

To close the valves and disconnect the couplers, reverse steps 1 through 4.

DISASSEMBLY INSTRUCTIONS

STAINLESS STEEL DRY MATE REBUILD INSTRUCTIONS *Applies to Male (A) half only*

1. Remove the endplate by holding the body with a bench vise and turning the endplate by the wrench flats. The endplate has right hand threads.
2. Remove the old seat that goes between the endplate and the ball.
3. Remove the ball. The handle should be in the open position when removing the ball. The ball should slide out easily.
4. Remove the old seat that goes between the body and the ball.
5. Remove handle nut, handle washer, handle, and handle interlock. Note orientation of handle and handle interlock.
6. Remove stem-packing nut and stem. Inspect stem for damage. Replace if necessary.
7. Remove old stem packing.
8. Install new stem packing, stem, and stem packing nut.
9. Reinstall handle interlock, handle, handle washer, and handle nut. Make sure safety button is in proper location with spring installed.
10. Install the new seat between body and ball.
11. Reinstall the ball. Check for pits, scrapes, or any other damage. If damaged or worn, replace ball.
12. Install new seat between endplate and ball.
13. Replace old body gasket with a new gasket.
14. Reinstall endplate on valve. Before tightening the endplate, make sure that the handle and ball are in the closed position. Tighten endplate to 325 Ft-lb of torque.
15. Check to make sure the dry mate half is functional and all the safety features are working properly.

DISASSEMBLY INSTRUCTIONS CONTINUED.

STAINLESS STEEL DRY MATE FACE SEAL REPLACEMENT INSTRUCTIONS *Applies to Female (D) half only*

1. Remove the endplate by holding the body with a bench vise and turning the endplate by the wrench flats. The endplate has right hand threads. Pay attention to the orientation of the locking yoke as you remove the endplate.
2. Remove the old seat that goes between the endplate and the ball.
3. Remove the ball. The handle should be in the closed position when removing the ball. The ball should slide out easily.
4. Remove the seat that goes between the body and the ball.
5. Remove handle nut, handle washer, handle, and handle interlock. Note orientation of handle and handle interlock.
6. Remove stem-packing nut and stem. Inspect stem for damage. Replace if necessary.
7. Remove old stem packing.
8. Install new stem packing, stem, and stem packing nut.
9. Reinstall handle interlock, handle, handle washer, and handle nut. Make sure safety button is in proper location with spring installed.
10. Install the new seat between body and ball.
11. Reinstall the ball. Check for pits, scrapes, or any other damage. If damaged or worn, replace ball.
12. Install new seat between endplate and ball.
13. Replace old body gasket with a new gasket.
14. Inspect and install locking yoke onto the body. Reinstall endplate on valve, checking to see that the orientation of the locking yoke matches the original orientation. Before tightening the endplate, make sure that the handle and ball are in the closed position. Tighten endplate to 325 ft-lb.
15. Replace face seal. Remove spiral ring and metal backup ring. Remove old seal. Reverse to install new seal.
16. Check to make sure the dry mate half is functional and all the safety features are working properly.

Please see banjocorp.com for more product drawings.



BANJO CORPORATION

A Unit of IDEX Corporation
150 Banjo Drive
Crawfordsville, IN 47933 U.S.A.
Telephone: (765) 362-7367
Tech Sales: (888) 705-7020
Fax: (765) 362-0744
banjocorp.com
#yellowhandle

